



# BURNDY®

## Washer, Electrical Equipment Bond

# WEEB® WASHER

## INSTALLATION INSTRUCTIONS

*For Unirac Solar Mount only*

Please read carefully before installing.

Burndy LLC recommends that the sufficient details of the installation be submitted to the AHJ for approval before any work is started.

<b>NOTICE</b>	
	<p>PLEASE READ CAREFULLY BEFORE INSTALLING</p>

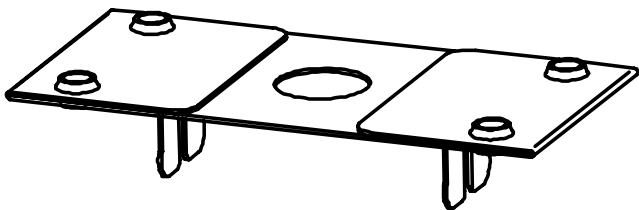

WEEB-UMC

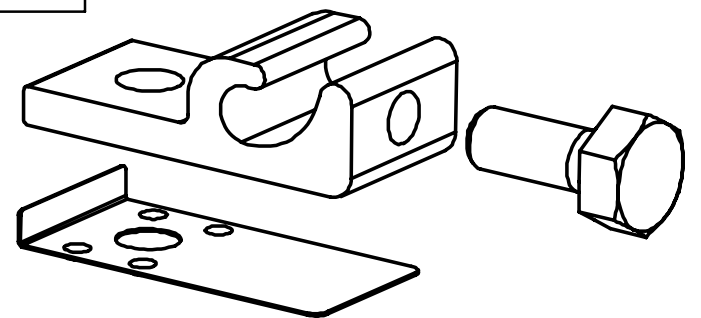

WEEB-LUG-6.7

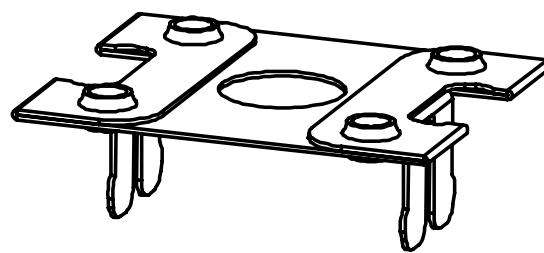

WEEB-DMC

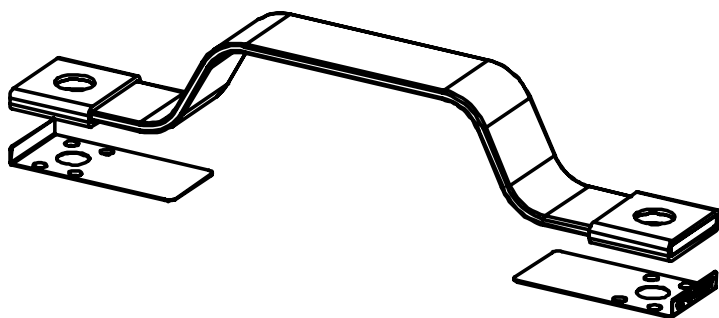

WEEB-BNDJMP6.7

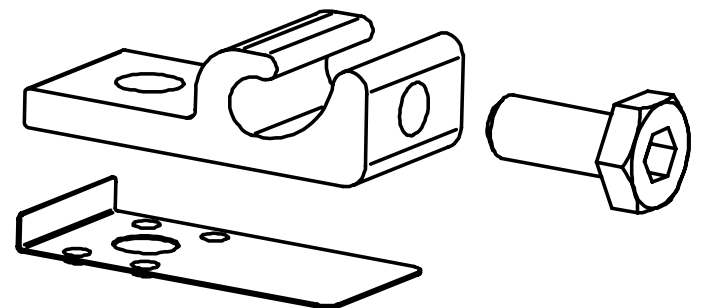

WEEB-LUG-6.7HS



System is ANSI/UL 2703 Listed for Grounding and Bonding.  
Products are ANSI/UL 467 Listed and CSA C22.2 No. 41 for Grounding and Bonding Equipment.



Intertek  
4004188



# WEEB-UMC COMPATIBILITY

The WEEB® washer family of products can be used to bond anodized aluminum, galvanized steel, steel and other electrically conductive metal structures. All installations shall be in accordance with NEC requirements in the USA and with CSA C22.1 in Canada. The WEEB® washers are for use with modules that have a maximum fuse rating of 25A or less.

Certain module frames do not have enough structural strength to withstand the force required to embed a WEEB® washer. These frames will deform and therefore not allow sufficient penetration of the WEEB® washer teeth. The general requirements for minimum module frame thickness of boxed" type module frames are illustrated below. For more information regarding module compatibility, please see the technical documents section of our website.

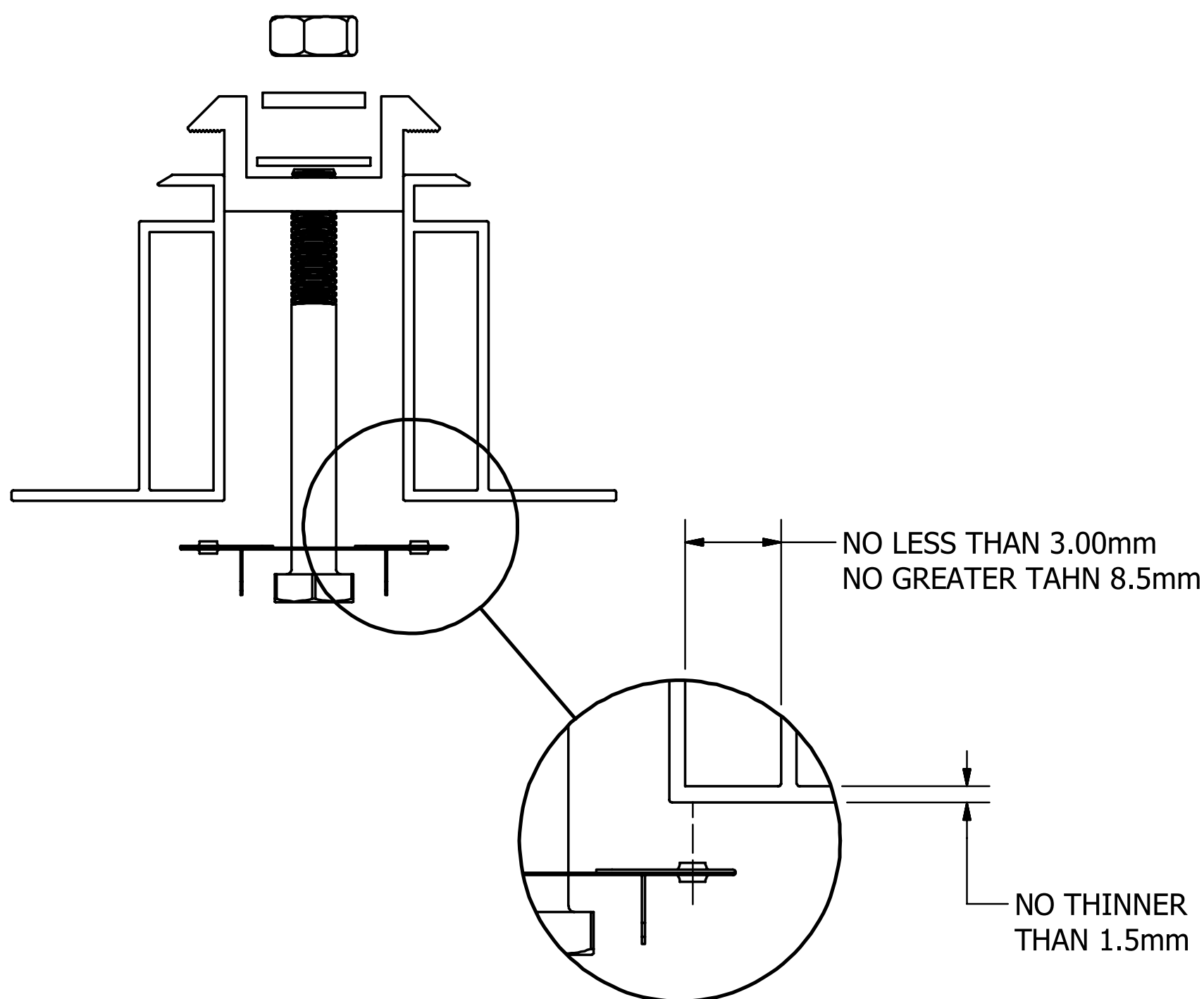

## Note:

Inspect each module frame used with a WEEB® device to ensure that the bottom mounting face of the frame is flat, and that there are no hindrances to embedding WEEB® washer teeth. Do not use a module with a frame that prevents the WEEB® washer teeth from embedding fully.

# SYSTEM OVERVIEW

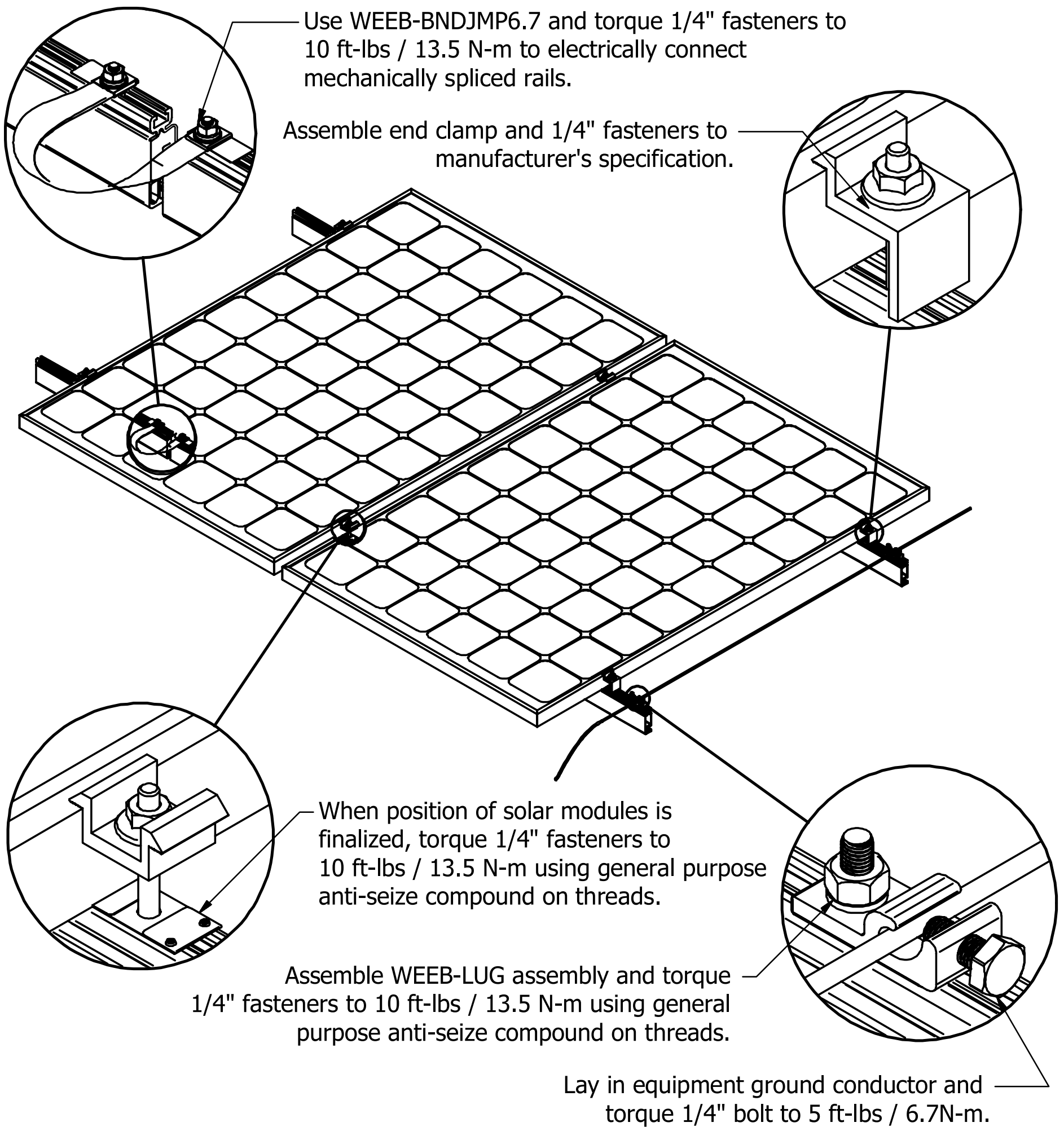

## Important notes:

1. Use general purpose anti-seize compound on fastener threads when installing WEEB<sup>®</sup> washers (unless already pre-applied).
2. Bond to ground path is accomplished through WEEB<sup>®</sup> washer, since midclamps and endclamps are not electrically bonded.
3. Secure PV cables and reliably route cables away from top down clamps using optional Wiley cable clips.

# WEEB-UMC LAYOUT

## EVEN NUMBER OF MODULES IN ROW

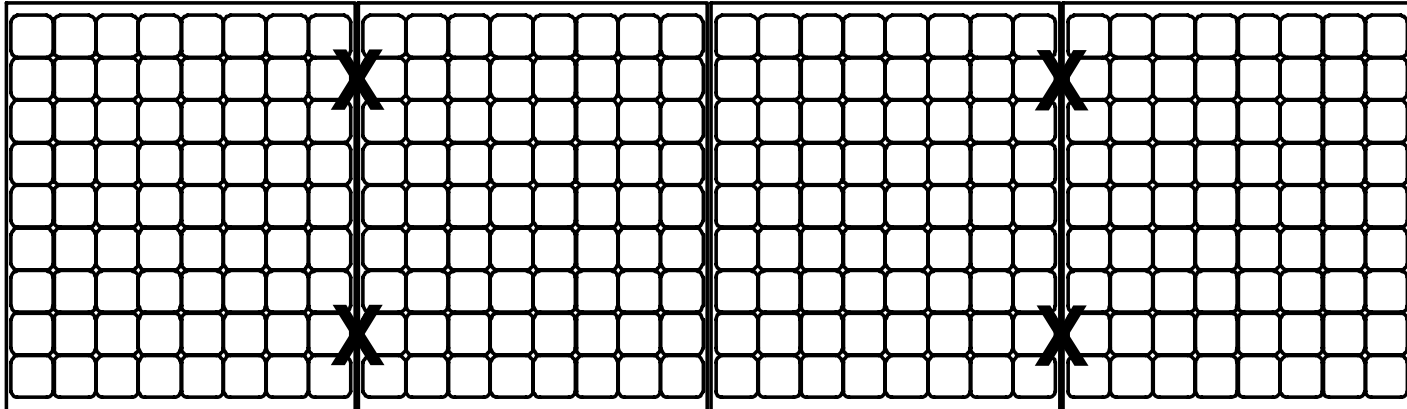

X DENOTES PLACES TO INSTALL WEEB-UMC

COLUMN X ROW = C X R = 4 X 1 = 4

WEEB-UMC NEEDED = 4

## ODD NUMBER OF MODULES IN ROW

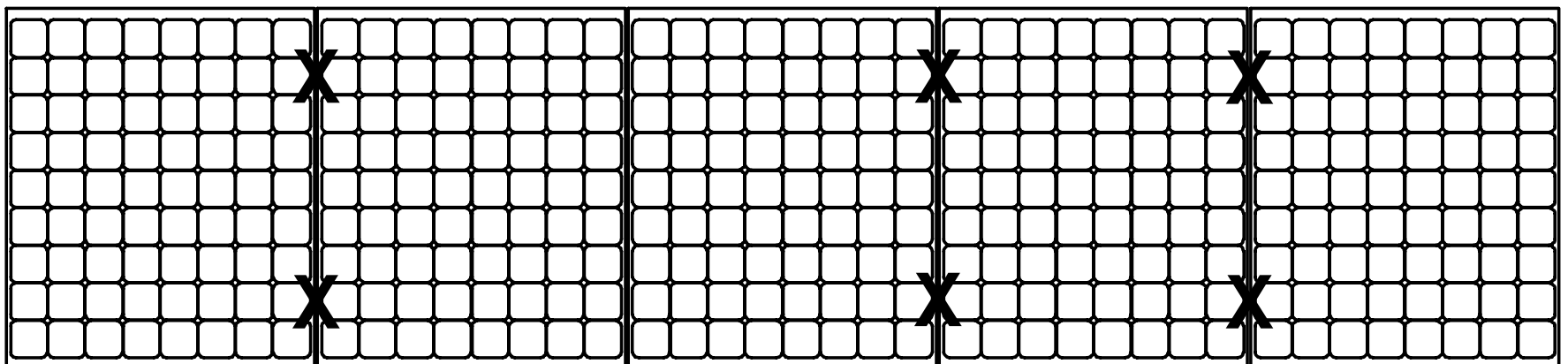

X DENOTES PLACES TO INSTALL WEEB-UMC

[ COLUMN + 1 ] X ROW = [ C + 1 ] X R = [ 5 + 1 ] X 1 = 6

WEEB-UMC NEEDED = 6

### Note:

When replacing a single faulty module, also remove the adjacent module which contacts the same WEEB® washers as the faulty module. This will ensure that there are never ungrounded modules in the array.

# SPLICE KIT ASSEMBLY

Install (1) WEEB-BNDJMP6.7 per splice to maintain electrical continuity between mechanically spliced rails.

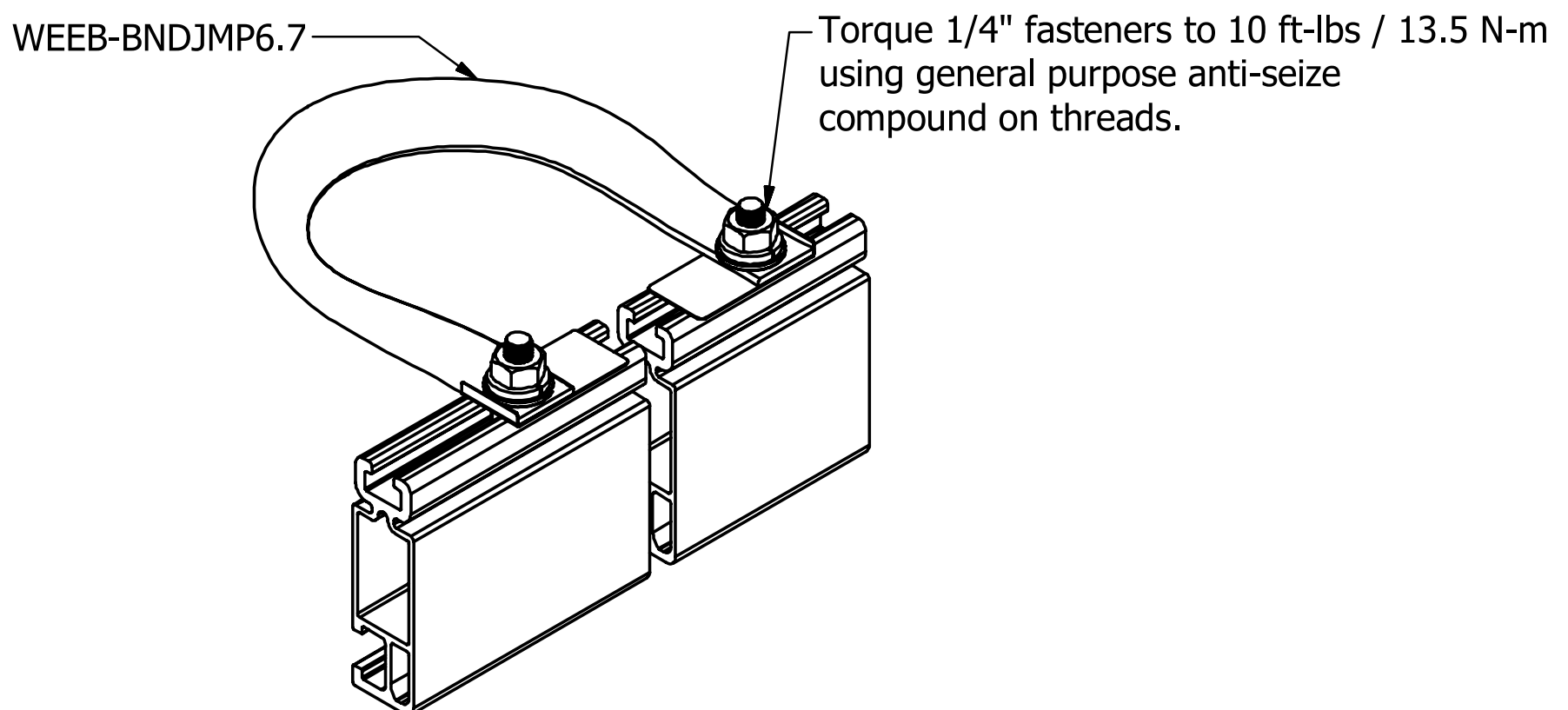
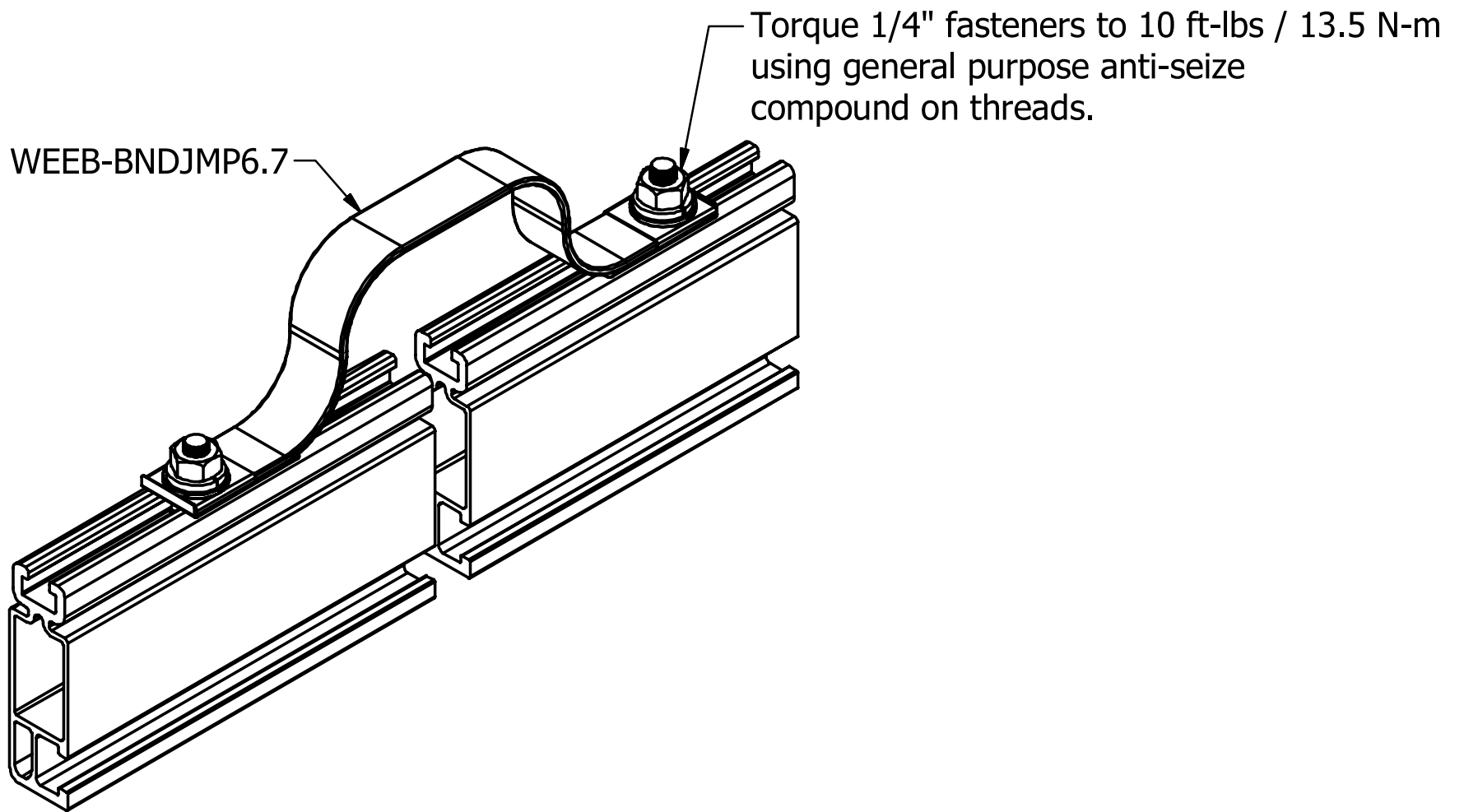

# LOW LIPPED MODULE INSTALLATION

Pre-assemble WEEB-DMC to mid clamp assembly using 1/4" hardware as shown. Pre-assembling WEEB-DMC to mid clamp assembly will contain the small individual parts, reducing the possibility of losing parts during installation.

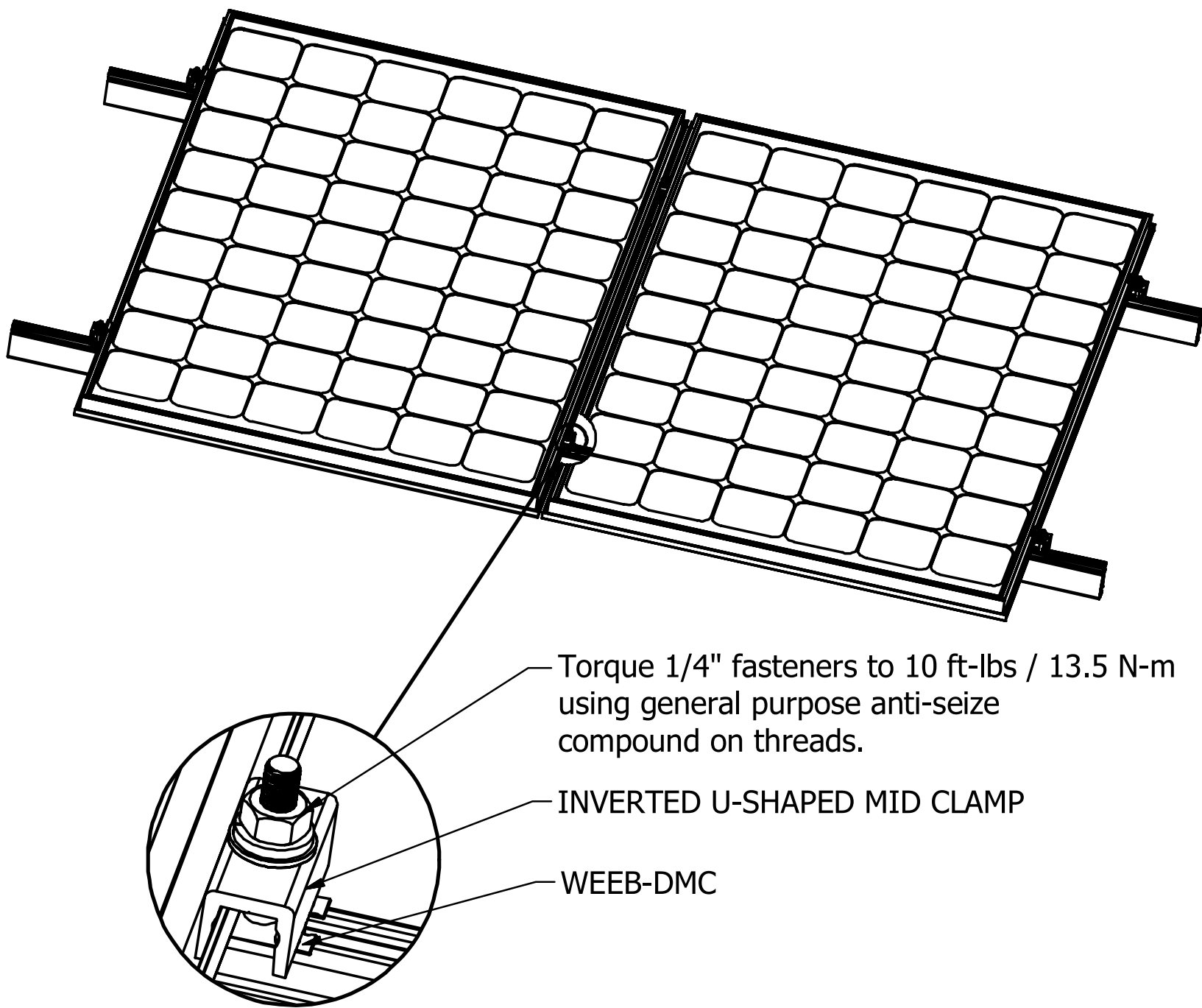
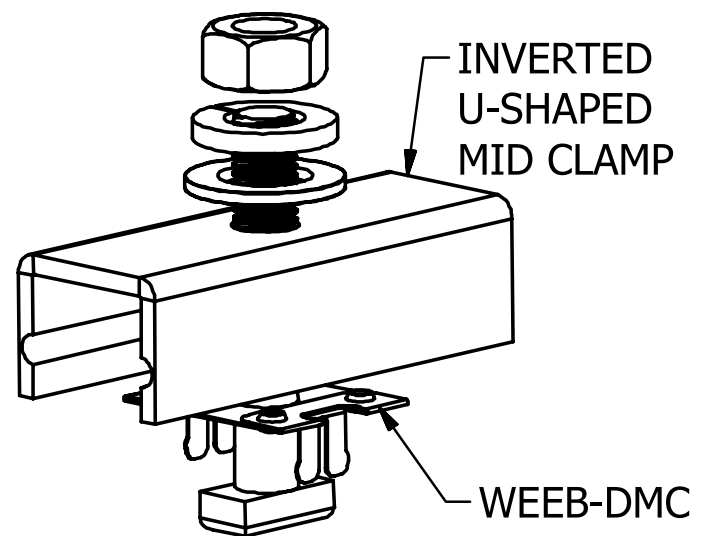

**Customer Service Department**  
7 Aviation Park Drive  
Londonderry, NH 03053  
1-800-346-4175  
1-603-647-5299 (International)